

Zähnezahl Z	Abmessungen in mm allgemein			Artikel-Nr. Ketten Fuchs								
				321-700- (+Zähnezahl)			322-700- (+Zähnezahl)			323-700- (+Zähnezahl)		
	de	dp		einfach			zweifach			dreifach		
	de	dp	dm	D1	A	dm	D1	A	dm	D1	A	
008	115,0	99,55	58,0	20,0	45,0	58,0	25,0	95,0	58,0	25,0	140,0	
009	126,4	111,40	70,0	20,0	45,0	70,0	25,0	95,0	70,0	25,0	140,0	
010	138,0	123,29	80,0	20,0	45,0	80,0	25,0	95,0	80,0	25,0	140,0	
011	150,0	135,21	90,0	25,0	50,0	90,0	25,0	100,0	90,0	25,0	150,0	
012	162,0	147,22	102,0	25,0	50,0	102,0	25,0	100,0	102,0	25,0	150,0	
013	174,2	159,18	114,0	25,0	50,0	114,0	25,0	100,0	114,0	25,0	150,0	
014	186,2	171,22	128,0	25,0	50,0	128,0	25,0	100,0	128,0	25,0	150,0	
015	198,2	183,26	140,0	25,0	50,0	140,0	25,0	100,0	140,0	25,0	150,0	
016	210,3	195,30	140,0	25,0	55,0	140,0	25,0	100,0	140,0	25,0	150,0	
017	222,3	207,34	140,0	25,0	55,0	150,0	25,0	100,0	150,0	25,0	150,0	
018	234,3	219,42	140,0	25,0	55,0	160,0	25,0	100,0	160,0	25,0	150,0	
019	246,5	231,49	140,0	25,0	55,0	160,0	25,0	100,0	160,0	25,0	150,0	
020	258,6	243,57	140,0	25,0	55,0	160,0	25,0	100,0	160,0	25,0	150,0	
021	270,6	255,65	150,0	25,0	60,0	160,0	25,0	100,0	160,0	30,0	150,0	
022	282,7	267,73	150,0	25,0	60,0	160,0	25,0	100,0	160,0	30,0	150,0	
023	294,8	279,80	150,0	25,0	60,0	160,0	25,0	100,0	160,0	30,0	150,0	
024	306,8	291,88	150,0	25,0	60,0	160,0	25,0	100,0	160,0	30,0	150,0	
025	319,0	304,00	150,0	25,0	60,0	160,0	25,0	100,0	160,0	30,0	150,0	
026	331,0	316,08	160,0	30,0	60,0	160,0	30,0	100,0	160,0	30,0	150,0	
027	343,2	328,19	160,0	30,0	60,0	160,0	30,0	100,0	160,0	30,0	150,0	
028	355,2	340,27	160,0	30,0	60,0	160,0	30,0	100,0	160,0	30,0	150,0	
029	367,3	352,38	160,0	30,0	60,0	160,0	30,0	100,0	160,0	30,0	150,0	
030	379,5	364,50	160,0	30,0	60,0	160,0	30,0	100,0	160,0	40,0	150,0	
031	391,6	376,62	160,0	30,0	60,0	170,0	30,0	100,0				
032	403,7	388,69	160,0	30,0	60,0	170,0	30,0	100,0	170,0	40,0	150,0	
033	415,8	400,81	160,0	30,0	60,0	170,0	30,0	100,0	170,0	40,0	150,0	
034	427,8	412,93	160,0	30,0	60,0	170,0	30,0	100,0	170,0	40,0	150,0	
035	440,0	425,04	160,0	30,0	60,0	170,0	30,0	100,0	170,0	40,0	150,0	
036	452,0	437,16	160,0	30,0	60,0	170,0	30,0	100,0	170,0	40,0	150,0	
037	464,2	449,27	160,0	30,0	60,0	170,0	30,0	100,0				
038	476,2	461,39	160,0	30,0	60,0	170,0	30,0	100,0	170,0	40,0	150,0	
039	488,5	473,50	160,0	30,0	60,0	170,0	30,0	100,0				
040	500,6	485,62	160,0	30,0	60,0	170,0	30,0	100,0	170,0	40,0	150,0	

Kettenrad 1 1/2 x 1"

für Rollenkette
nach DIN-Nr. 8187
ISO/R 606

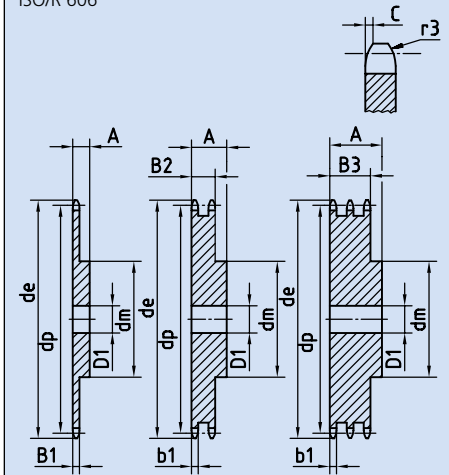

*Kettenräder mit angeschweißter Nabe

Kettenrad	ISO mm	ASA-120 mm
Zahnkopfrundung r ₃	38	40,5
Breite der Rundung C	4	4,8
Zahnkranzbreite B ₁	24,1	23,5
Zahnkranzbreite b ₁	23,6	22,9
Zahnkranzbreite B ₂	72	68,3
Zahnkranzbreite B ₃	120,3	113,7
Kette	mm	mm
Teilung	38,1	38,1
innere Breite	25,4	25,4
Rollen-Ø	25,4	22,22

Zähnezahl Z	Abmessungen in mm			Zähnezahl Z	Abmessungen in mm		
	allgemein de	dp			allgemein de	dp	
008	115,0	99,55		044	549,0	534,08	30,0
009	126,4	111,40		045	561,2	546,20	30,0
010	138,0	123,29		046	573,3	558,32	30,0
011	150,0	135,21		047	585,4	570,43	30,0
012	162,0	147,22		048	597,4	582,55	30,0
013	174,2	159,18		049	609,5	594,66	30,0
014	186,2	171,22		050	621,7	606,78	30,0
015	198,2	183,26		051	633,8	618,89	30,0
016	210,3	195,30		052	646,0	631,01	30,0
017	222,3	207,34		053	658,0	643,13	30,0
018	234,3	219,42		054	670,2	655,28	30,0
019	246,5	231,49		055	682,3	667,40	30,0
020	258,6	243,57		056	694,4	679,51	30,0
021	270,6	255,65		057	706,5	691,63	30,0
022	282,7	267,73		058	718,6	703,74	30,0
023	294,8	279,80		059	730,7	715,86	30,0
024	306,8	291,88		060	742,8	727,97	30,0
025	319,0	304,00		062	767,2	752,24	40,0
026	331,0	316,08		064	791,3	776,48	40,0
027	343,2	328,19		065	803,4	788,59	40,0
028	355,2	340,27		066	815,6	800,71	40,0
029	367,3	352,38		068	839,8	824,89	40,0
030	379,5	364,50		070	864,2	849,21	40,0
031	391,6	376,62		072	888,4	873,48	40,0
032	403,7	388,69		075	924,8	909,83	40,0
033	415,8	400,81		076	936,9	921,98	40,0
034	427,8	412,93		080	985,4	970,44	40,0
035	440,0	425,04		085	1046,0	1031,10	40,0
036	452,0	437,16		095	1167,3	1152,33	40,0
037	464,2	449,27					
038	476,2	461,39					
039	488,5	473,50					
040	500,6	485,62					
041	512,6	497,74					
042	524,7	509,85					
043	536,8	521,97					

Kettenradscheibe 1 1/2 x 1"

für Rollenkette
nach DIN-Nr. 8187
ISO/R 606

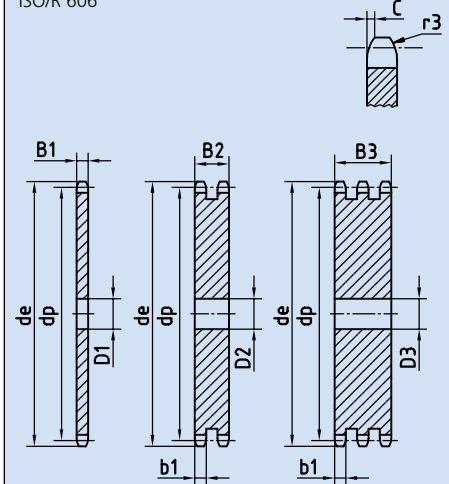

Kettenradscheibe	ISO mm	ASA-120 mm
Zahnkopfrundung r ₃	38	40,5
Breite der Rundung C	4	4,8
Zahnkranzbreite B ₁	24,1	23,5
Zahnkranzbreite b ₁	23,6	22,9
Zahnkranzbreite B ₂	72	68,3
Zahnkranzbreite B ₃	120,3	113,7
Kette	mm	mm
Teilung	38,1	38,1
innere Breite	25,4	25,4
Rollen-Ø	25,4	22,22